

IN SINK ERATOR®

Model 78

0.75 Horsepower

Food Waste Disposer

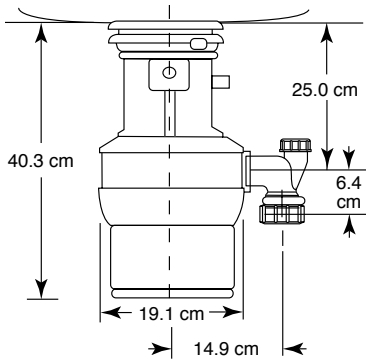

NOTE: Plumb waste line to prevent standing water in disposer motor housing.

Submittal Sheet

- .75 HP Dura-Drive™ heavy-duty induction motor
- Batch-feed operation
- 3 year full warranty*
- Two-way grinding action for trouble-free operation
- Stainless steel grind chamber for great durability
- Upper-end bell with corrosion shield guards against caustic action of detergents
- Cast stainless steel 360° swivel lugs, copper-infiltrated
- Permanently lubricated upper and lower bearings
- Quick-Lock™ mounting assembly for faster, easier installation
- Polished stainless steel sink flange
- Batch sink stopper and switch
- Overload protection - manual reset switch
- Stainless steel shredder ring for increased grinding efficiency
- Stainless steel rotating shredder
- Jam-buster wrenchette included to free any jams

Specifications

Type of Feed	Batch	
On/Off	Part of stopper	
Motor	Induction, Split Phase	
Horsepower	0.75	
Volts (V)	220-240	230-240
Hertz (Hz)	50	50
RPM	1425	1425
Average Load	405 W	405 W
Lubrication	Permanently lubricated upper & lower bearings	
Shipping Weight	9.115 kg	
Unit Finish	Gray Enamel	
Overall Height	40.3 cm	
Grind Chamber Capacity	1,705 mL	
Motor Protection	Manual reset overload	
Average Water Usage	1 L per person per day	
Average Electrical Usage	0.5 Kilowatt-Hour per month	
Dishwasher Drain Connection	Yes	

Sample Specification

Food Waste Disposer(s) shall be: In-Sink-Erator Model 78, batch feed, with .75 H.P. motor, stainless steel grinding elements with two cast stainless steel 360° swivel lugs. Self-service wrenchette. 3 year full warranty.

* The complete In-Sink-Erator warranty is included in the Care & Use Booklet, packed with each unit.

Separate user manual also included.

Job Specifications

