

IN SINK ERATOR®

Model 75 0.75 Horsepower

Food Waste Disposer

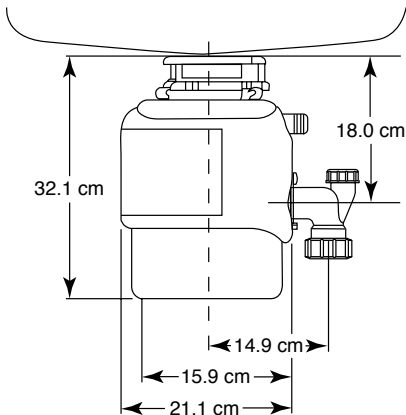

NOTE: Plumb waste line to prevent standing water in disposer motor housing.

Submittal Sheet

- .75 HP Dura-Drive™ heavy-duty induction motor
- Continuous-feed operation
- 5 year full warranty*
- Two-way grinding action for trouble-free operation
- Ultra Quiet II System: double sound baffles, large shell protection, deluxe acoustical foam insulation with integral sound barrier
- Stainless steel grind chamber for great durability
- Upper-end bell with corrosion shield guards against caustic action of detergents
- Cast stainless steel 360° swivel lugs, copper-infiltrated
- Permanently lubricated upper and lower bearings
- Quick-Lock™ mounting assembly for faster, easier installation
- Polished stainless steel sink flange
- 1-Piece stainless steel sink stopper resists corrosion
- Overload protection - manual reset switch
- Stainless steel shredder ring for increased grinding efficiency
- Stainless steel rotating shredder with bolted connection for corrosion protection
- Jam-buster wrenchette (with clip holder) included to free any jams
- Built-in Air Switch

Specifications

Type of Feed	Continuous		
On/Off	Wall Switch or Air Switch (included)		
Motor	Induction, Split Phase		
Horsepower	0.75		
Volts (V)	220-240	230-240	120
Hertz (Hz)	50	50	60
RPM	1425	1425	1725
Average Load	405 W	405 W	8.1 A
Lubrication	Permanently lubricated upper & lower bearings		
Shipping Weight	8.920 kg		
Unit Finish	Gray Enamel		
Overall Height	32.1 cm		
Grind Chamber Capacity	1,405 mL		
Motor Protection	Manual reset overload		
Average Water Usage	1 L per person per day		
Average Electrical Usage	0.5 Kilowatt-Hour per month		
Dishwasher Drain Connection	Yes		

Sample Specification

Food Waste Disposer(s) shall be: In-Sink-Erator Model 75, continuous feed, with .75 H.P. motor, stainless steel grinding elements with two cast stainless steel 360° swivel lugs. Self-service wrenchette. 5 year full warranty.

* The complete In-Sink-Erator warranty is included in the Care & Use Booklet, packed with each unit.

Separate user manual also included.

Job Specifications

