

# IN SINK ERATOR®

## Model 65 0.65 Horsepower

## Food Waste Disposer

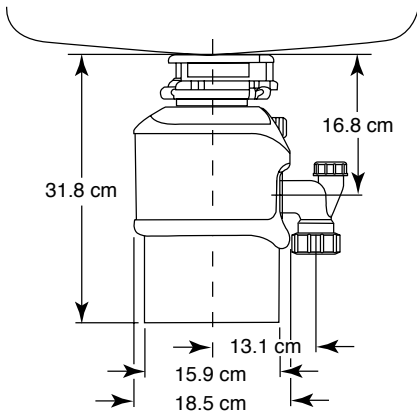

NOTE: Plumb waste line to prevent standing water in disposer motor housing.

### Submittal Sheet

- .65 HP Dura-Drive™ heavy-duty induction motor
- Continuous-feed operation
- 4 year full warranty\*
- Two-way grinding action for trouble-free operation
- Quiet Plus System: double sound baffles, large shell protection, premium acoustical foam insulation
- Engineered resin grind chamber won't corrode
- Cast stainless steel 360° swivel lugs
- Permanently lubricated upper and lower bearings
- Quick-Lock™ mounting assembly for faster, easier installation
- Polished stainless steel sink flange
- 1-Piece stainless steel sink stopper resists corrosion
- Overload protection - manual reset switch
- Stainless steel shredder ring for increased grinding efficiency
- Stainless steel rotating shredder with bolted connection for corrosion protection
- Jam-buster wrenchette included to free any jams
- Built-in Air Switch (not on 120 V models)

### Specifications

<b>Type of Feed</b>	Continuous		
<b>On/Off</b>	Wall Switch or Air Switch (included on 220-240V model)		
<b>Motor</b>	Induction, Split Phase		
<b>Horsepower</b>	0.65		
<b>Volts (V)</b>	220-240	230-240	120
<b>Hertz (Hz)</b>	50	50	60
<b>RPM</b>	1425	1425	1725
<b>Average Load</b>	405 W	405 W	8.1 A
<b>Lubrication</b>	Permanently lubricated upper & lower bearings		
<b>Shipping Weight</b>	8.205 kg		
<b>Unit Finish</b>	Gray Enamel		
<b>Overall Height</b>	31.8 cm		
<b>Grind Chamber Capacity</b>	980 mL		
<b>Motor Protection</b>	Manual reset overload		
<b>Average Water Usage</b>	1 L per person per day		
<b>Average Electrical Usage</b>	0.5 Kilowatt-Hour per month		
<b>Dishwasher Drain Connection</b>	Yes		

### Sample Specification

Food Waste Disposer(s) shall be: In-Sink-Erator Model 65, continuous feed, with .65 H.P. motor, stainless steel grinding elements with two cast stainless steel 360° swivel lugs. Self-service wrenchette. 4 year full warranty.

\* The complete In-Sink-Erator warranty is included in the Care & Use Booklet, packed with each unit.

Separate user manual also included.

### Job Specifications

